

ETER 9908

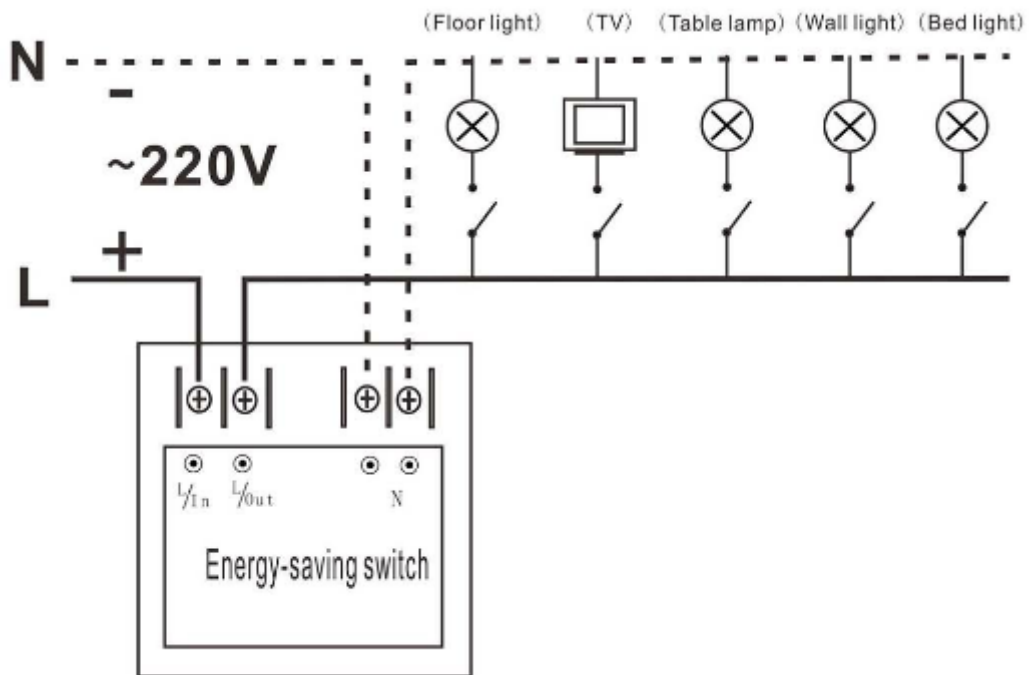

Dimensioni

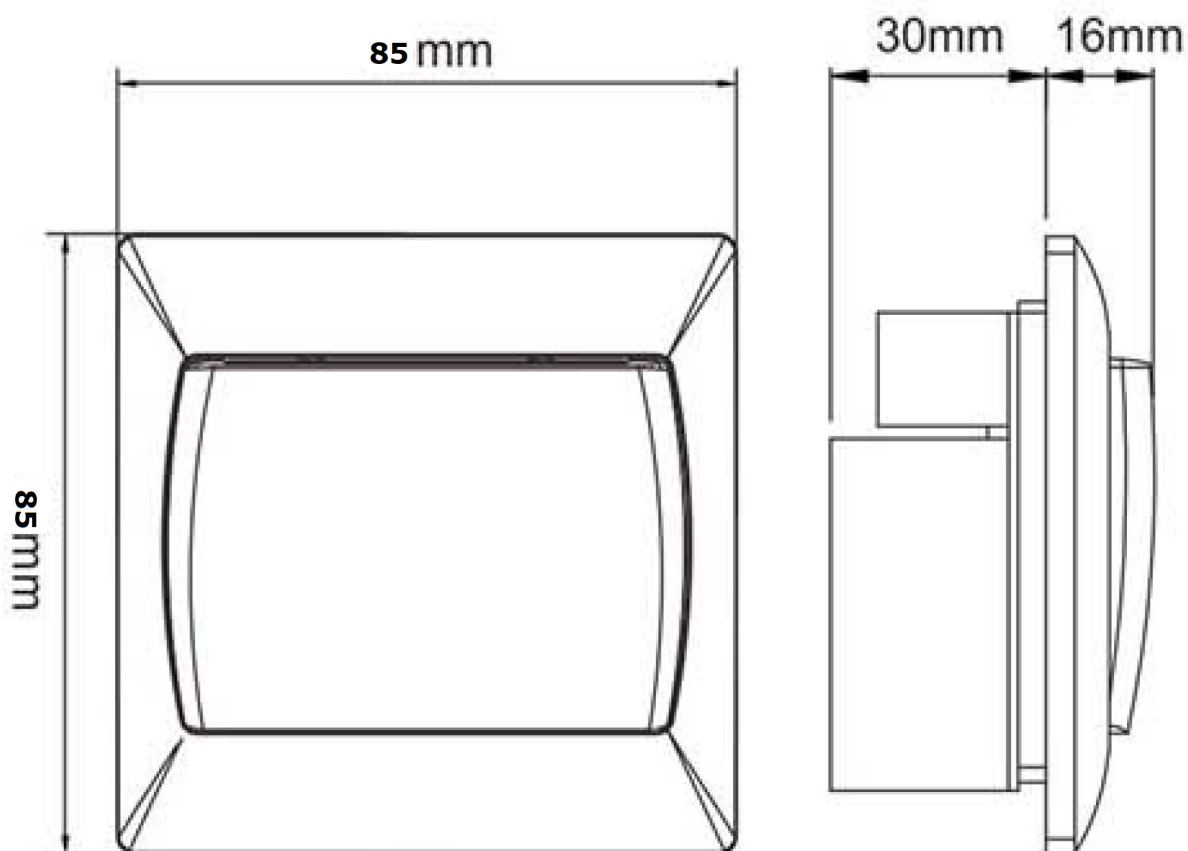

Caratteristiche tecniche

Tensione di lavoro	AC 220V+10%
Corrente massima	30A
Potenza totale di carico	6600W
Consumo	1W
Ritardo risparmio energetico	Circa 15 secondi
Inattività	Indicata in rosso
Rivestimento	Resistente al fuoco
Peso	1.709g